



SDB

DOUBLE PURIFIER



Fluid dynamic optimization for perfect product stratification. Stackability. Stability guaranteed by an alternative motor. Uniform distribution of the product on the sieve. Ideal machine for purifying semolina.

Variable suction chamber grading sectors depending on the product layer on the sieve.

Suction regulated by 32 valves with patented wing profile for independent control and regulation of air along the entire length of each quarter of the sieve.

Inclined suction chamber to ensure perfect cleaning.

Double machine, three rows of 500x500 mm sieves and two independent suction chambers.

Drive, with a single motor, by means of rotating masses and a toothed transmission belt which guarantees perfect synchronism between the eccentric masses both in the power/stop transition phase and at working speed.

Product inlet connected to the suction chamber to obtain product stratification before it reaches the sieve. The suction chamber is fixed while the underlying layering structure is in motion.

A version with two stacked purifiers with independent suction is also available, extremely useful in small buildings.



Technical Information

Model	Dimensions (mm)				Sieves			Motor		Lamp	Suction	Net weight (Kg)	Packaging volume (m ³)
	A	B	C	D	Total number	Dimensions (mm)	Net sifting Area (m ²)	Installed power (kW)		Installed power (kW)	Air flow rate (m ³ /min)		
								50 Hz	60 Hz				
SD 500	1280	1471	2755	1602	24	500 x 500	5,3	0,75	0,86	2 x 0,036	40 - 50	1140	7,9
SDB 50S	1650	3070	2755	2945	24 + 24	500 x 500	5,3 + 5,3	2 x 0,75	2 x 0,86	4 x 0,036	2 x 40 - 50	2650	8,4

The technical characteristics of the machines are subject to change without notice. The data may not be fully compliant with the commercialized versions.

SDB 500

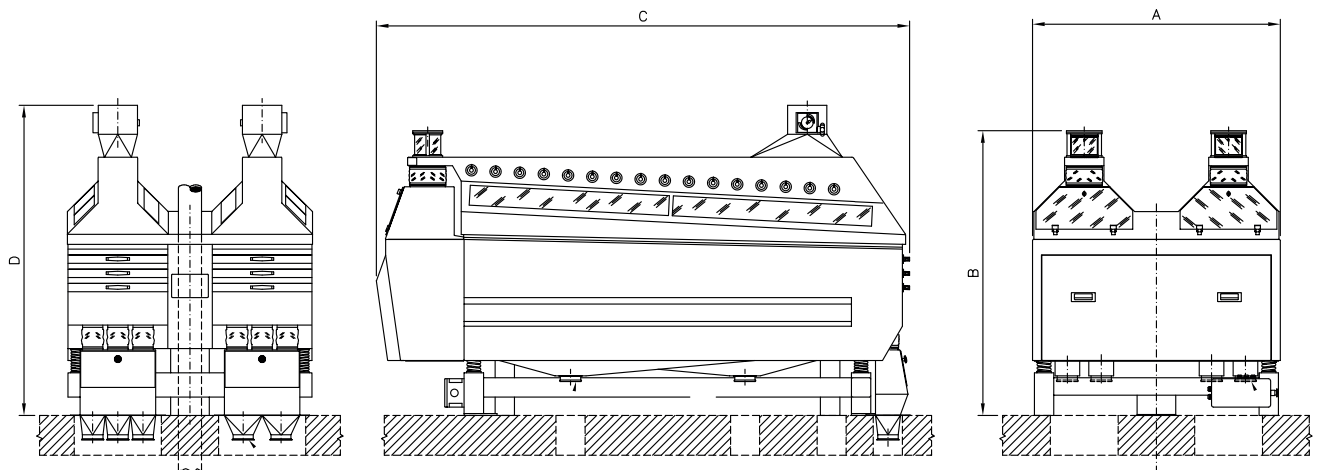

SDB 50S

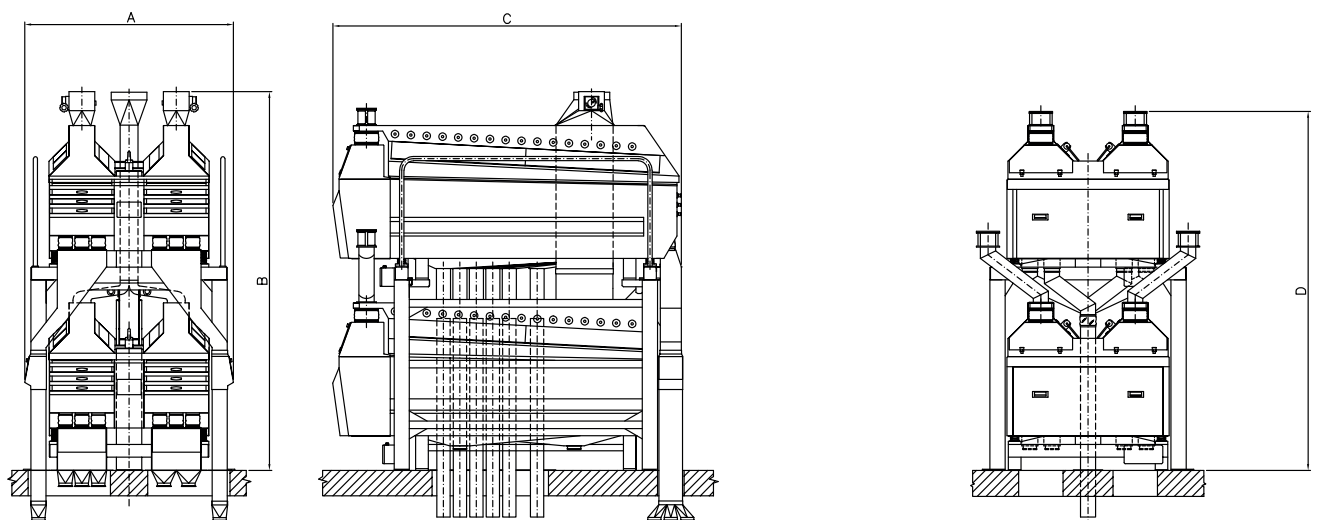

OCRIM

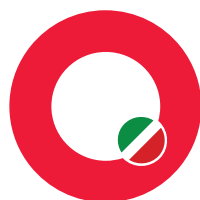

OCRIM S.p.A. - Via Massarotti, 76 - 26100 Cremona (Italy)



www.ocrim.com