



TDV

GRAVITY SEPARATOR

Separates two products of same size but different specific gravity by the floating principle.

The unit selects cereals, broken grains, durum wheat semolina, maize and wheat germ, seeds, oil-seeds, coffee beans, peas, beans, nuts, and can be simultaneously employed as a stoner.

Totally enclosed, vacuum operated machine consisting of a supporting frame, an oscillating deck, an exhaust hood and a feed control device.

The selected products are conveyed to an outlet having four fixed outlets and three diverting valves for products division.

Oscillating frame with aluminium working deck covered with easily removable wire mesh or stainless steel screen.

Constant loading is ensured by the feed group provided with a spring loaded valve for air-tight operation. Large polycarbonate windows allow visual control of working deck.

The technological setting up can be performed with machine in operation by means of devices adjusting the longitudinal and cross angle.

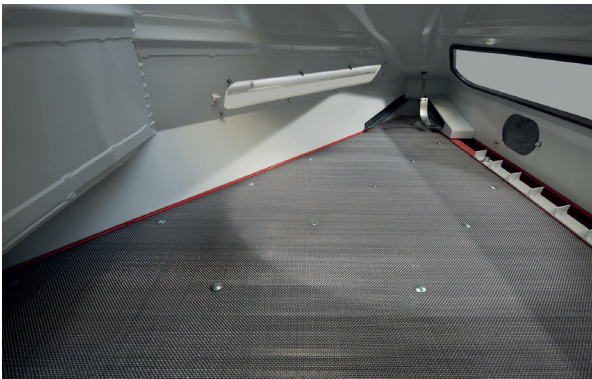

Optional – Autoregulation system

The “load control” system provides a continuous flow meter placed at the exit of the selected product and a control unit equipped with the touch panel.

Operation is simple and intuitive: once properly adjusted the gravity separator and stored the reference value, the PLC activates a control loop via an inverter that feeds the vibromotors. This system automatically handles the adjustment of the machine so that variations in flow or density does not affect the optimal and constant quality of the selected products.

Technical information

Model	Dimensions (mm)					Maximum capacity (T/h)				Installed power (KW)			Exhaust (m ³ /min)	Net weight (kg)	Shipping volume (m ³)
	A	B	C	D	ØE	Wheat	Maize (brevery grits)			Vibromotors		Lamp			
							Coarse	Medium	Fine	50 Hz	60 Hz				
TDV 150	1706	1474	1960	1955	350	2,5	1,5	1,5	1,3	2x0,75	2x0,45	0,018	85÷120	480	5,8
TDV 200	2190	1834	2078	2090	450	3,5	2,2	2,2	2	2x0,75	2x0,45	0,018	120÷140	540	8,4

Technical features of the equipment can be modified without any obligation of notice. Data may be not fully in accordance with the market versions.

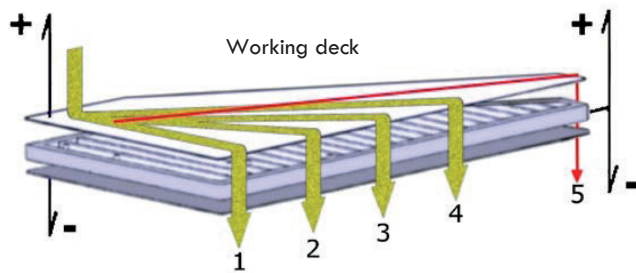

Wheat	Maize
1 – Light screenings	1 – Germ
2 – Recycle	2 – Recycle
3 – Recycle	3 – Medium grits
4 – Products	4 – Coarse grits
5 – Stones	5 – Stones

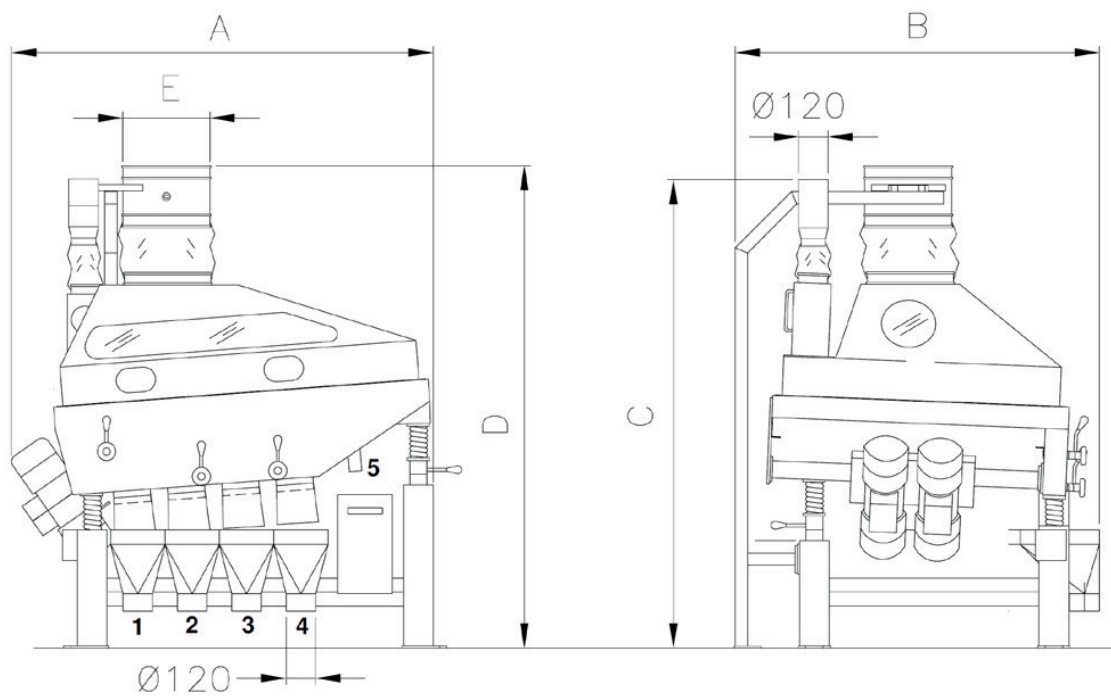

OCRIM

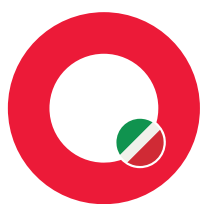

OCRIM S.p.A. - Via Massarotti, 76 - 26100 Cremona (Italy)



www.ocrim.com